

# Cascade 65 Collaboration Display (65" Diagonal)

Cascade video walls and displays deliver an unrivaled collaboration experience. Totally immersive and engaging, they enable a new generation of multi-purpose conference rooms. The large, integrated digital canvas allows users to share, annotate, and edit office docs, web apps, multimedia files, and video from multiple simultaneous sources including PCs and mobile devices. Content can be positioned and resized dynamically through multi-user touch. These capabilities offer a breakthrough collaboration experience that raises team productivity and engagement to a new level.

For more information, contact us at [sales@prysm.com](mailto:sales@prysm.com), 1.877.99.PRYSM or +1.408.586.1100.

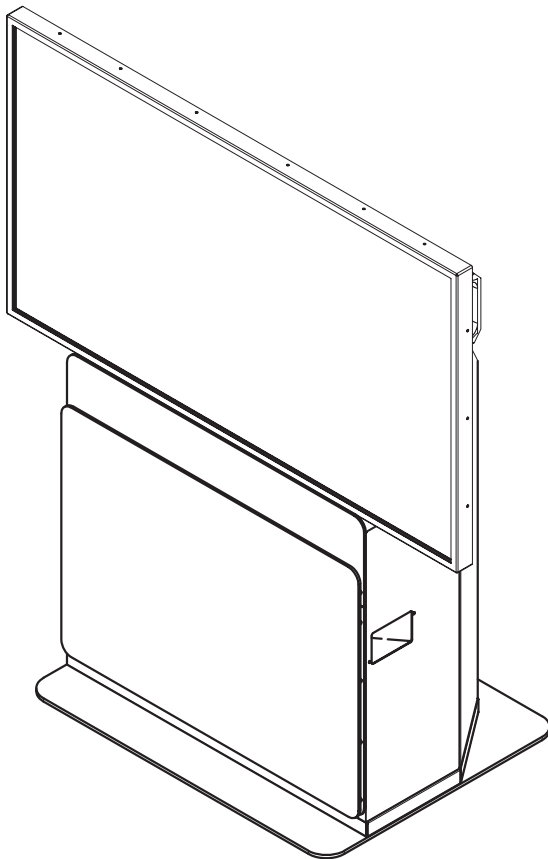

## Target Applications

Room Types	Conference rooms Team spaces Board rooms Briefing centers Training rooms Demo centers
Room Size	Small rooms, 2 – 6 people
Ambient Light	Suitable for normal indoor ambient lighting conditions (avoid direct sunlight)

## Display Characteristics

Display Resolution (W × H, pixels)	3840 × 2160
Refresh Rate (Hz)	100/120
Max Input Resolution and Frame Rate	3840 × 2160 @ 60Hz
Total Pixel Count (M)	8.3
Display Active Area (in)	56.2 (W) × 31.6 (H) × 64.5 (diagonal)
Display Active Area (mm)	1428 (W) × 804 (H) × 1638 (diagonal)
Display Aspect Ratio (width/height)	16 : 9
Display Color	>1 billion colors, 10 bit data path
Panel Brightness (cd/m <sup>2</sup> )	350 (typical)
Panel Contrast Ratio	5000:1
Backlight Illumination	Edge LED
Response Time (ms)	6.5 (typical)
Pixel Pitch (mm)	0.37 × 0.37
Ideal Viewing Distance (ft)	3 – 20
Ideal Viewing Distance (m)	1 – 6
Display Dimensions (in)	58.4 (W) × 33.5 (H) × 3.1 (D)
Display Dimensions (mm)	1484 (W) × 852 (H) × 79 (D)
Cover Glass	Corning® Gorilla® glass Chemically-strengthened, 2mm Zero air gap
Touch Type	High-resolution IR
Touch Points	12 simultaneous touch points
Touch Resolution	Sub-pixel
Touch Update Rate (fps)	200
Touch Latency (ms)	5 – 10
Touch Accuracy (mm)	2.7
Audio	Two rear facing speakers, 10 W each

## Display Environmental

Weight (lbs.)	132.3
Weight (kg)	60
Power Consumption - Display Only (W)	Max: 280 typical: 210 standby: ≤ 0.5
Heat Output (BTU/hr)	Max: 955 typical: 717
Operating Temperature	41 – 104 °F (5 – 40 °C)
Storage Temperature	-4 – 140 °F (-20 – 60 °C)
Humidity	Up to 90% RH (non-condensing)
Power Supply (V)	AC 100 – 240
IP Rating	50

...cont'd on reverse

**Regulatory**

FCC	FCC CFR Title 47 Part 15 Subpart B: Class A, CISPR 22 ANSI C63.4 ICES-003 Issue 5
CE	EN 55022, EN 55024, EN 61000-3-2, EN 61000-3-3
cTUVus	UL 60950-1 CAN/CSA-C22.2 NO.60950-1-07
CB	IEC 60950-1
CCC	GB9254, GB4943.1, GB17625.1
CEL	GB21520

**Collaboration Appliance**

Typical Features <sup>1</sup>	Video capture (input) <sup>2</sup> : 2x HDMI 1.4a (max. 8 inputs) Output: 1x DisplayPort 1.2 Processor: Intel i7 RAM: 16 GB HD: 2x 512 GB SSD (RAID 1) Dimensions (W x H x D): 19.0 in x 7.0 in x 15.0 in (483 mm x 177 mm x 381 mm) Interactive Input Controller kit <sup>3</sup> (x1)
-------------------------------	---

<sup>1</sup> For feature description and additional configuration options please refer to the Prysm Synthesis Specification Sheet.  
<sup>2</sup> Video capture inputs are optional.  
<sup>3</sup> Enables display and control of remote laptop/desktop from Cascade display. Requires purchase of the optional Interactive Input Controller kit and video capture card for input to collaboration appliance.

**Display Stand**

Design	Modern
Electronics Storage (RU)	10
Interior Rack Width (in)	19.0
Interior Rack Width (mm)	483
Interior Rack Depth (in)	15.0
Interior Rack Depth (mm)	381
Exterior Width (in)	35.0
Exterior Width (mm)	889
Exterior Depth (in)	25.6
Exterior Depth (mm)	650
Weight (lbs)	200
Weight (kg)	90.7

**Wall Mount**

VESA (mm)	400 x 400
-----------	-----------

**Clearances**

Minimum Ceiling Height	96.0 in (2438 mm)
Display Start Height	32.5 in (825 mm)
Required Clearances— Passive Ventilation	Front: 12.0 in (300 mm) Rear: 8.0 in (200 mm)

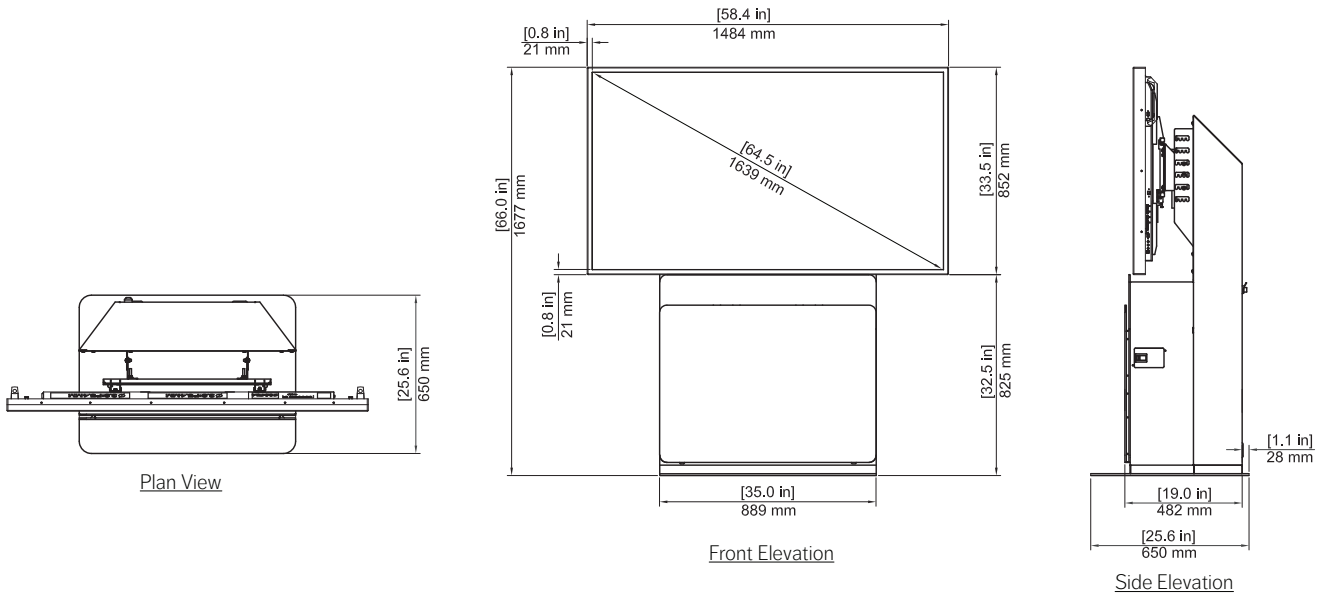

Dimensions [in] mm

**Disclaimer:**

The information contained herein is subject to change without notice. The only warranties for Prysm products and services are set forth in the express warranty statements accompanying the applicable customer agreement. Nothing herein should be construed as constituting an additional warranty. This document is provided solely for general informational purposes. Prysm shall not be liable for technical or editorial errors or omissions contained herein.