

» CP307-RS «



Intel® Core™ (2) Duo 3U CompactPCI CPU board

» **High performance**

based on Intel®'s dual-core technology

» **Versatile SATA and RAID functionality**

4x Rear IO SATA interfaces with RAID 0/1/5/10 support

» **Comprehensive I/O capabilities**

Gigabit Ethernet, USB, VGA, Compact Flash...

CP307-RS

CompactPCI for high storage demands

RAID technology has become an essential element for meeting the escalating industry requirements for higher storage capacity, performance and data reliability. Therefore RAID-Systems and storage solutions based on CompactPCI are more and more requested in the different market segments.

The CP307-RS, a single slot 3U CompactPCI board, is especially designed to feed these growing demands. The feature set of the board is tailored to performance and functionality at the same time:

The board comes with a high performance Intel® dual-core processor, either an Intel® Core™ Duo running at 1.66 GHz or an Intel® Core™ 2 Duo running at 1.5 GHz. Intel®'s dual-core technology is optimized for multi-threaded applications and multitasking and delivers the needed performance to build up and manage the RAID arrays.

The mobile chipset 945GM Express together with the ICH7R lay the foundations for the RAID storage by providing a comprehensive SATA and RAID functionality.

Versatile system architectures

The RAID levels 0 (striping), 1 (mirroring), 5 and 10 are supported by the chipset ICH7R. This capability in conjunction with 4x SATA ports routed to Rear I/O enables the CP307-RS to be used as RAID controller in a number of different applications.

Customers can choose between best performance by striping the data on different volumes or utmost security through data mirroring or parity control.

In safety applications and video surveillance systems for example the usage of RAID technology is mandatory. Just these systems must run without failure, record and save the data – very often hundreds of Gigabytes – and ensure the video availability when needed.

Comprehensive I/O Connectivity

The CP307-RS comes with a comprehensive I/O connectivity supporting communication interfaces like 2x Gigabit Ethernet, 4x USB 2.0 ports, 4x SATA interfaces and 2x serial ports (RS232).

To be able to use the communication interfaces from the rear of a CompactPCI system a dedicated rear transition module - CP-RI03-RS – has been designed.

Longterm Availability

Investing in a new project is always a challenge and risky. Extending the lifetime of an application to the possible maximum is therefore a critical issue to save the development investments. Delivering a stable product based on Intel®'s embedded product line the CP307-RS ensures long term availability. This eliminates the risk of unplanned design changes and unexpected expensive application modification. While minimizing deployment risks by providing a broad range of software support the CP307-RS eases the process of product integration and maximizes your competitive advantage to meet your time-to-market window.

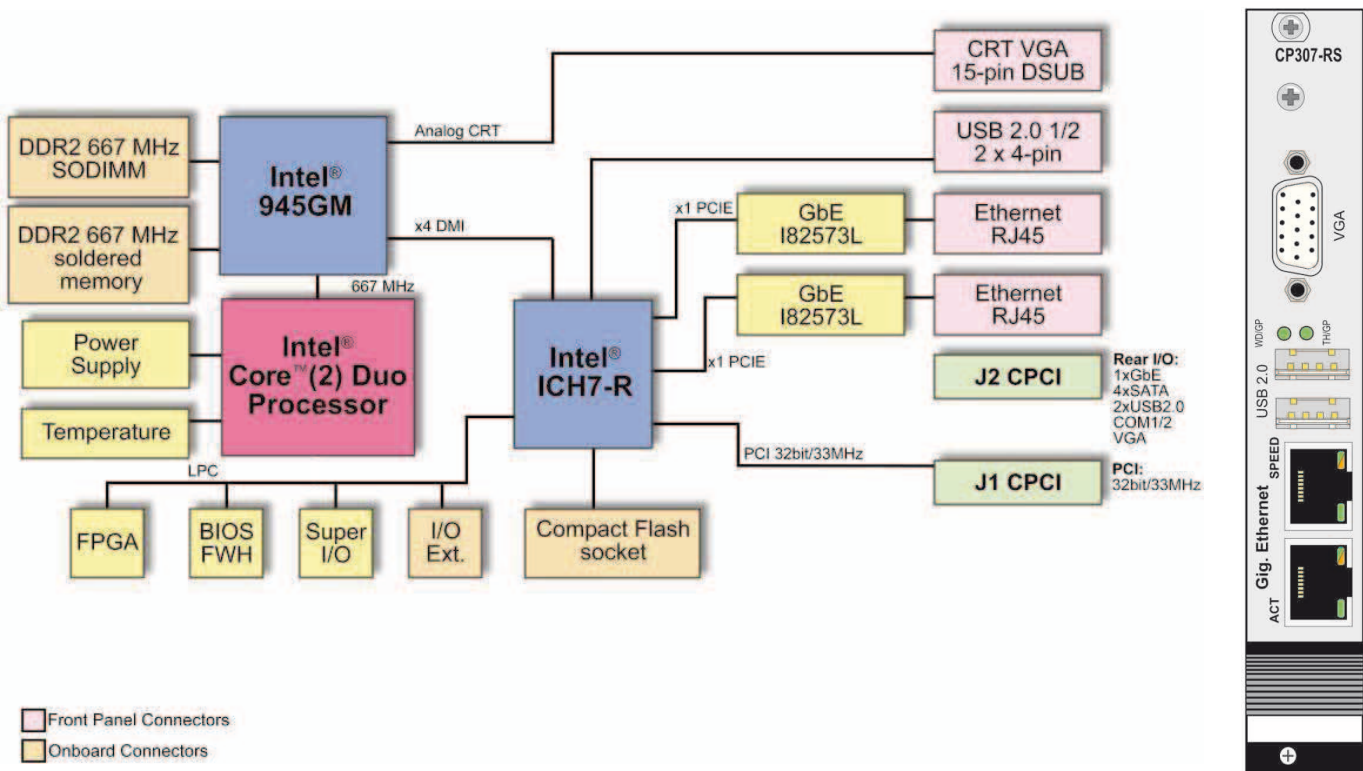

Technical Information

Processor

Intel® Core™2 Duo processor in micro-FCBGA package (65nm manufacturing process):
 - L7400: LV 1.5 GHz, 667 MHz FSB, 4 MB L2 cache
 Intel® Core™ Duo processor in micro-FCBGA package (65nm manufacturing process):
 - L2400: LV 1.66 GHz, 667 MHz FSB, 2 MB L2 cache

All board versions are passive cooled with a heatsink within 4HP height
 Forced air cooling at a specific flow rate is required depending on the processor version

Memory

System memory:	Up to 4GByte dual channel DDR2 667 MHz memory, ¹⁾ via max. 2GByte soldered and SODIMM-socket for max. 2 GByte memory module (no ECC)
Flash (BIOS):	1 MByte Firmware hub (FWH)
EEPROM:	Serial EEPROM (24LC64) 64 kbit for CMOS data storing (no battery operation)
CompactFlash:	Type I and Type II mounting within 4HP via mezzanine module

Onboard Controller

GMCH Graphic Memory Controller Hub:	Intel® 945GM chipset Dual-channel DDR2 memory controller, Internal graphics controller with dual independent VGA channels
I/O Controller Hub:	Intel® ICH7R 4 x SATA II ports with RAID functionality (0,1,5,10) 6 x USB 2.0, 2 x PCI-Express x1, 1x 32-bit/33MHz PCI master interface
VGA:	Integrated in 945GM max. 2048 x 1536 pixels (QXGA), 16M colors, @75Hz, max. 265MByte memory used from system memory
Gigabit Ethernet:	2 x GbE Front or Rear (s/w switchable), 82573L PCI-Express controller
Super I/O:	LPC Super I/O SMSC SCH3112I-NU with 2x UART, HWMonitor, PS/2
Watchdog:	Timeout ranging from 125ms to 256s programmable in 12 steps NMI, IRQ, Reset, dual-stage
RTC:	Integrated in ICH7R with 256 bytes of battery-backed CMOS RAM

Front Panel Interfaces

VGA:	1 x VGA-CRT 15-pin D-Sub connector
USB:	2 x USB 2.0 ports, 4-pin standard USB connectors
Ethernet:	2 x RJ45 with integrated LEDs (ACT, SPEED)
LEDs:	1x Thermal, Watchdog or both general purpose

Rear I/O via J2

The CP307-RS supports:
 - 32-bit/33 MHz CompactPCI interface
 - Two USB 2.0 ports
 - One Gigabit Ethernet port without LED signals
 - Four SATA ports
 - Two COM ports (3. 3V TTL level)
 - One VGA analog port
 - One fan control input
 - One PWM output
 - Management and control signals
 - Input for +5V standby power

CompactPCI Bus Interface

PICMG 2.0 Rev. 3.0 compatible, 32-bit/33MHz System master
 universal 5V and 3.3V PCI signalling voltage supported, 7 Req/Gnt & clock lines

Supervisory Functions

Watchdog, software configurable, 125ms to 256s in 12 steps, generates IRQ, NMI or hardware reset,
 two stage configuration for NMI and Reset
 Hardware monitoring SCH3112 for thermal control, fan-sense/control and all important onboard voltages

Hot Swap

Support for all signals to allow peripheral boards to be hot swapped. The individual clocks for each slot and access to the backplane ENUM# signal comply with the PICMG 2.1 Hot-Swap specification.

Compliance

CompactPCI Core Specification PICMG 2.0 Rev. 3.0
 CompactPCI Hot Swap Specification PICMG 2.1 R2.0
 Designed to meet or exceed:
 - Safety: UL 1950, UL 94, CSA 22.2 No 950, EN 60950, IEC 950
 - EMI/EMC: EN 55022 / EN 55024, EN 50081-1 / EN 6100-6-2

General

Dimensions:	100 x 160mm, 3U, 4HP
Weight:	320g
MTBF:	276,140 h acc. to MIL-HDBK 217FN2, Ground Benign GB, controlled at 30°C

¹⁾ 4 GB minus the allocated memory for DVMT, PCI/PCIe devices and the video controller memory address space of 256 MB

Technical Information

Software Support

- AMI BIOS with POST codes, setup console redirection to serial port (VT100 mode) with CMOS setup access, BIOS parameters saved in EEPROM, diskless, keyboardless, LAN boot support
- Board identification number accessible via EEPROM
- Support for Windows® XP, XP Embedded, Linux®, VxWorks (other OSs may be possible, please contact us for information)

Power Consumption

L2400 LV 1.66 GHz and 1GB memory	typ. 18W
L7400 LV 1.5 GHz and 1GB memory	typ. 20W

Environmental

Operating temp.:	0°C to +60°C, passive module heat sink, forced system airflow required
Storage temp.:	-55°C to +85°C (without battery)
Climatic Humidity:	93% RH at 40°C, non-condensing (acc. to IEC 60068-2-78)

Ordering Information

Article	Order-No.	Description
CPU Baseboard + Frontpanel		
CP307-RS-1.6D-2GD-U-4HP	1031-3860	L2400 1.66 GHz, 2MB L2, 1GB soldered + 1GB SODIMM, Rear I/O, universal, with frontpanel
CP307-RS-1.5D-2GD-U-4HP	1031-3848	L7400 1.5 GHz, 4MB L2, 1GB soldered + 1GB SODIMM, Rear I/O, universal, with frontpanel
Rear Transition Modules		
CP-RI03-RS	1031-3676	4HP rear I/O module (1x Ethernet, 2x USB, VGA, 4x SATA connectors)
CP-RI03-RS	1031-3677	8HP rear I/O module (additional to 4HP COM1/2)
Software		
KIT-CP307 ¹⁾	33997	Windows XP Board Support Package, CP307 User's Manual
LIN-BSP-CP307 ¹⁾	33998	Linux Board Support Package, CP307 User's Manual
WXPE-BSP-CP307 ¹⁾	1022-3521	Windows XP embedded Board Support Package, CP307 User's Manual

Notes:

- ¹⁾ Free of charge, downloadable from the Internet
Please contact your local sales representative for other configuration options.

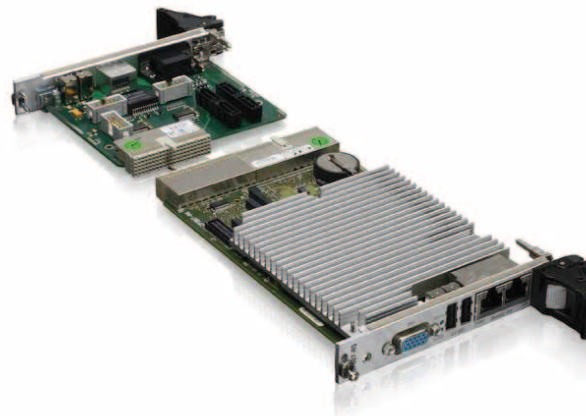

CORPORATE OFFICES

Europe, Middle East & Africa

Oskar-von-Miller-Str. 1
85386 Eching/Munich
Germany
Tel.: +49 (0)8165/ 77 777
Fax: +49 (0)8165/ 77 279
info@kontron.com

North America

14118 Stowe Drive
Poway, CA 92064-7147
USA
Tel.: +1 888 294 4558
Fax: +1 858 677 0898
info@us.kontron.com

Asia Pacific

17 Building, Block #1, ABP.
188 Southern West 4th Ring Road
Beijing 100070, P.R.China
Tel.: + 86 10 63751188
Fax: + 86 10 83682438
info@kontron.cn

